

doi: 10.26529/cepsj.451

Development of an Albanian Version of the Questionnaire on Teacher-Student Interaction

EDONA BERISHA KIDA*¹ AND THEODHORI KARAJ²

~ A questionnaire for studying teacher-student interaction in Albanian contexts was developed with extensive coverage in the field of educational psychology. The purpose was to adapt and develop an Albanian version of the widely used tool, the Questionnaire on Teacher-Student Interaction. The teacher-student relationship has been found to be very significant in many studies. Students' academic achievements, emotional and social development, classroom group dynamics, and school dropouts are just some of the issues to be influenced by the nature of the established teacher-student relationship. To better measure students' perceptions of teachers, clinical scientific data on personality interactions have been adapted and transferred to the contexts of education. With a sample of 300 subjects, the Questionnaire on Teacher-Student Interaction underwent necessary procedures and statistical analyses. Consequently, the original American version of 64 items resulted in 54 items in the Albanian version. Results confirm the reliability and validity of the questionnaire in the Albanian language and reconfirm its general usage for diverse cultures and contexts. Finally, through this study, the dimensions of teacher-student interactions were also measured and documented in the Kosovo context.

Keywords: Albanian version of the QTSI, dynamics of human interaction, students' perceptions of teachers in primary schools, validity of the QTSI, psychometric approach to measuring circular data

1 *Corresponding Author. Faculty of Education/Pristine University, Kosovo; edona.berisha-kida@uni-pr.edu.

2 Faculty of Social Sciences, University of Tirana, Albania.

Razvoj albanske različice vprašalnika o interakciji med učiteljem in učencem

EDONA BERISHA KIDA IN THEODHORI KARAJ

≈ Oblikovan je bil vprašalnik za preučevanje interakcij med učiteljem in učencem v albanskih kontekstih z obsežnim pokrivanjem na področju pedagoške psihologije. Namen je bil prilagoditi in razviti albansko različico široko uporabljenega orodja, t. i. vprašalnika o interakciji učitelja in učenca (QTSI). V veliko raziskavah je bila ugotovljena ključna vloga odnosa med učiteljem in učencem. Akademski dosežki učencev, čustveni in socialni razvoj, skupinska dinamika v razredu in osip so le nekatera vprašanja, na katera vpliva narava vzpostavljenega odnosa med učiteljem in učencem. Da lahko bolje izmerimo, kako učenci dojemajo učitelje, so klinični znanstveni podatki o osebnostnih interakcijah prilagojeni in preneseni v kontekst izobraževanja. Na vzorcu 300 učencev je vprašalnik o interakciji učitelja in učenca preстал potrebne postopke in statistične analize. Posledično se je izvirna ameriška različica, ki sicer vsebuje 64 elementov, izražala v 54 elementih albanske različice. Rezultati kažejo na zanesljivost in veljavnost vprašalnika v albanskem jeziku ter ponovno potrjujejo njegovo splošno uporabo v različnih kulturah in kontekstih. S to študijo smo tudi merili in dokumentirali dimenzije interakcij med učitelji in učenci v kosovskem kontekstu.

Ključne besede: albanska različica QTSI, dinamika človekove interakcije, dožemanja učiteljev z vidika učencev v osnovnih šolah, veljavnost QTSI, psihometrični pristop k merjenju krožnih podatkov

Introduction

Human interaction

The effect of social interaction on the development and dynamics of personality has become an area of interest that is addressed by many disciplines of psychology such as behavioural, social, organisational, educational psychology, the psychology of communication, among others.

Social interaction is essential for the development of basic cognitive concepts to the more complex ones such as the development of self-concept. The mutual relationship of human interaction, the way individual psychology is socially influenced, and the way human behaviour further influences the social context are explained through different theories. For example, theories of psycho-social development (led by Erikson, 1959, 1963) have explained the development of personality at different stages by overcoming psycho-social crises; psychodynamic theories have explained how social interaction influences emotional development; behaviourism and social learning theories (including the cognitive perspective in education) have explained how individuals develop the cognition and learning processes through social context interaction; systemic theories involving the ecological and family perspectives have explained the dependency of behaviour on macro and microsystems, among others. (Ginsburg & Opper, 1969; Vata, Haith, & Miller, 2007).

Later, social psychologists addressed research issues related to the way how the social context and inner experiences, such as thoughts (cognition) and emotions (affective domain), predict individual behaviour (Fisher, Fraser, & Cresswell, 1995).

The impact of interpersonal relationships on the individual's psyche is also addressed in the field of clinical psychology. Leary's interpersonal relationship model (1957) is perhaps the most accepted and proven to be effective in the clinical field (Strack, 1996). This model introduces two-dimensional dynamics of human interaction, one of the domination/control and the other of proximity/love. Studies show that this model is applicable on the intercultural basis (Wubbels, Den Brok, Van Tartwijk, & Levy, 2012).

The importance of knowing the teacher-student relationships

Through his experiments Norman Triplett (1897) documented that as a result of competitive drives, the individual's efforts increase by the presence of another person (but decreases by the group growth and responsibility sharing); the impact of human interaction as a promoter or deprivation of success became a reference focal point for studies (Fisher et al., 1995).

Given the fact that social interaction affects the development of personality in different forms, while personal traits and concepts affect the individual's performance, educational psychology began to study the influence of social contexts and, in particular, the impact of teacher-student relationships and other classroom dynamics on cognitive and emotional processes (Fisher et al., 1995; Den Brok, 2001; Den Brok, Fisher, & Rickards, 2006).

The social comparison theory states that depending on personal experiences, an individual forms thoughts of self (self-concept), according to which he/she develops certain positive or negative feelings toward him/herself. Self-concept and self-esteem are formed by psychic responses to interpersonal, developmental experiences, to further directly influence the behaviour and success of the individual (Fisher & Richards, 1998; Frenzel, Goetz, Lüdtke, Pekrun, & Sutton, 2009). Therefore, the learning process that is part of various developmental phases has started to be elaborated through an interpersonal perspective. This perspective addresses communication systems and teacher-student relationships that have been shown to influence not only cognitive but emotional processes as well (Frenzel et al., 2009; Fried, Mansfield, & Dobozy, 2015).

Academic achievements, emotional, and social development, and the number of school dropouts are just some of the issues shown to be influenced by the nature of established relationships between students and teachers (Den Brok, 2001; Fisher & Rickards, 1998; Frenzel et al., 2009; Fraser et al., 2010; Fried et al., 2015; Muller, Katz, & Dance, 1999).

The students' cognitive results proved to be closely related to the friendly, supportive, leading, and strict behaviour of teachers. The more friendly, supportive, leading and strict the behaviour of the teacher is, the greater the students' success and vice versa (Fisher et al., 1995; Fisher & Rickards, 1998). Thus, interpersonal behaviour has been shown to be a strong aspect of the learning environment, and it is akin to the academic achievements of students.

Psychological Model of Human Interaction in the Educational Context and Development of the Questionnaire for Teacher-Student Interaction (QTSI)

Wubbels, Creton, and Hooymayers in 1985 laid the foundations of the Teacher Interpersonal Behaviour Model (TIBM) (Wubbels et al., 1985). They expanded Leary's (1957) idea of a clinical model for personality diagnosis based on interpersonal behaviour. The TIBM is built on two dimensions of interpersonal interaction between teachers and students. This model is presented in Figure 1. Its dimensions are 1) the proximity dimension that varies between cooperative and

opposite behaviour, and 2) the influence dimension that varies between dominant and submissive behaviour. These dimensions are placed within a coordinate axis: the influence dimension as the dominant-submissive (DS) line is placed in the vertical axis while the proximity dimension as the cooperative-opposition (CO) line on the horizontal axis (Fisher & Rickards, 1998; Wubbels et al., 2012).

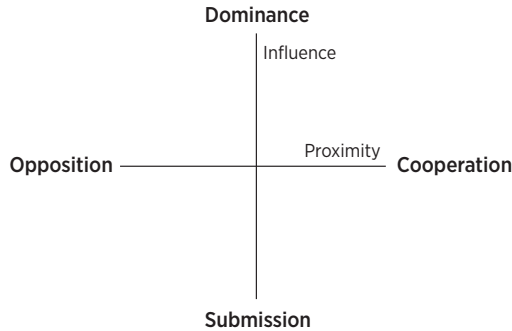

Figure 1. TIBM Model within the Coordinate Axis

Different sectors exhibiting specific behaviour conform to the variability within the coordinate axis are set and form a circle (circular) presented in Figure 2. The variable behaviours on the coordinate axis are Leader, Supportive/Friendly, Understanding, Student’s Responsibility, Uncertain, Unsatisfied, Admonishing, and Strict Behaviour (Den Brok, Fisher, & Rickards, 2006, 1998; Wubbels & Brekelmans, 2005).



Figure 2: Interaction model in the educational context. Model for interpersonal teacher behaviour. Adapted from Wubbels & Brekelmans, 2005, p. 9.

As can be seen in Figure 2, the two dimensions are presented through two axes, which extend the eight types of teacher behaviour. The characteristics of this model are eight sectors of behaviour that are presented in two dimensions; the two dimensions are negatively correlated; sectors can be equally distributed in the circumplex.

One sector has the highest correlation with the nearest sector within the circumplex and the lowest correlation with the reverse ones. Sectors are named depending on the position within the coordinate axis. For example: being a leader and supportive/cooperative; both types of these behaviours are characterised by dominance (D) and cooperation (C), but in the first case (being a leader) dominance predominates cooperation (DC), while in the second case (being supportive/cooperative) the opposite occurs (CD) (Den Brok et al., 2006).

To accurately measure students' perceptions of teachers and the development of their interpersonal relationships, Wubbles and his colleagues developed the Questionnaire on Teacher-Student Interaction (QTSI), which further supported the TIBM model (Wubbels et al., 2012). The TIBM model is well reflected in the questionnaire, with which certain types of interaction are measured under different subtests. Despite representing students' perceptions of teachers' interaction habits, QTSI is also useful to enable teachers' to reflect upon their classroom behaviours and to use its findings as a basis for behavioural modification. Comparison of the results on the **Ideal Self** (which can be presented if the teacher fills out the questionnaire by alluding to what he/she would like his/her professional performance to be), the **Real Self** (filling out the questionnaire on a maximum realistic way by the teachers) and the **Self perceived by students** (when the QTSI is filled out by the students) would further support reflection on the dynamics of teachers' interactive habits and professional work (Fisher & Rickards, 1995, 1998).

Adaptations of the QTSI Questionnaire

Following the initial QTSI application in the Netherlands, it was supported and adapted from many countries such as Australia, Canada, Greece, Israel, Slovenia, Serbia, Turkey, Korea, Taiwan, Indonesia, Singapore and United States (Den Brok et al., 2006).

The Dutch, American, and Australian versions of QTSI were developed after several pilot administrations and statistical analysis to achieve satisfactory psychometric traits (Wubbles & Brekelmans, 2005; Wubbles et al., 2012). The Dutch version, as the first and the original one, possessed 77 questions; the American one was reduced to 64 while the Australian version to 48 questions (Wubbels, Brekelmans, & Hermans, 1987; Wubbels & Levy, 1991).

QTSI has eight sub-tests. Answers are designed according to the Likert scale, from 'Never' to 'Always'.

Several studies have been conducted on the reliability and validity of the QTSI, where Cronbach's Alpha was always higher than .70. The intercultural validity of the questionnaire (of the American version) was confirmed by Wubbles and Levy (1991) in a sample involving over 1600 students and approximately 100 teachers (Fisher & Rickards, 1998; Wubbels et al., 2012).

For more than 20 years, QTSI has been consistently reported to be an effective instrument for measuring teacher-student relationships (Den Brok et al., 2006; Passini, Molinari, & Speltini, 2015; Wubbels et al., 2012). Passini et al. documented QTSI's validity and reliability in different adaptations. This is summarised in Table 1 below.

Table 1

Psychometric properties of QTSI in different versions and adaptations.

Language	Version	N	References	Cronbach Individual (from-to)	Cronbach Class Mean (from-to)	Ability to differentiate between class	Circumplex structure
Dutch	77 Items	1105	Wubbles and Levy (1993)	.74-.85	-	-	-
English (Australian)	48 Items	3215	Richards and Fisher (1999)	.62-.88	.72-.92	.17-.31	-
English (Australian)	64 Items	726	Den Brok et al. (2006)	.56-.86	.76-.96	.22-.35	Partially confirmed
English (Australian)	64 Items	3994	Fisher et al. (1997)	.63-.88	-	.22-.35	-
English (Singapore)	48 Items (primary)	1512	Chiew Goh and Fraser (1998)	.50-.78	.73-.96	.13-.38	-
English (US)	64 Items	1606	Wubbels and Levy (1991)	.76-.84	-	-	-
French	64 Items	799	Lapointe and Legauk (1999)	.68-.93	-	-	Partially confirmed
French	32 Items	1764	Lapointe and Legauk (1999)	.62-.85	.89-.98	-	Partially confirmed
Greek	64 Items (primary)	1973	Kyriakides (2005)	-	.84-.94	-	Confirmed
Greek	48 Items	273	Kokkimos et al. (2009)	.36-.76	-	.12-.44	Confirmed
Hebrew	64 Items	113	Kremer-Hayon and Wubbles (1993)	.57-.83	-	-	-
Malay	64 Items	2357	Den Brok et al. (2006)	.57-.83	.75-.95	-	Partially confirmed
Malay	48 Items (primary)	3104	Scott and Fisher (2004)	-	.62-.86	.14-.24	Partially confirmed
Korean	48 Items	543	Kim et al. (2000)	.61-.83	-	.14-.25	Confirmed
Turkish	64 Items	674	Telli et al. (2007)	.74-.97	-	.24-.45	-

Note. Adapted from Passini et al., 2015.

Current study objectives

The main objective of this study is:

1. To adapt the American version of QTSI to the Albanian language.

The further supporting objective is:

2. To apply the QTSI-Albanian version and represent an overview of students' perceptions of teachers' interaction habits in elementary schools of Kosovo.

Research questions

1. To what extent does the construction of the QTSI Albanian version fit with the American version?
2. What are the elementary school students' perceptions of their teachers' interaction habits in Kosovo?

Method

Characteristics of Sample

The data collection was a sample of 300 students with the following demographic characteristics: 145 females and 155 males, ranging from the 1st to the 5th grade (approx. 6-10 years old), coming from five municipalities, 10 different schools (see Tables 3) and 49 different classes (49 different teachers). The municipalities were: Prishtina, Fushë-Kosova, Obilic, Podujeva, and Drenas. For convenience in the application procedure and greater accuracy in the results, the sample had more students from the 3rd, the 4th, and the 5th grades (see Tables 2). During the administration of the questionnaire, direct support was offered to all respondents in need.

Table 2
Sample distribution by class

Class	Frequency
I	36
II	40
III	81
IV	82
V	61
Total	300

Table 3
Sample distribution by schools

No.	School	Frequency
1	Xhemail Mustafa	30
2	Pavaresia	30
3	Meto Bajraktari	29
4	Iliria	36
5	Daut Bogujevci	30
6	Dëshmoret e Kombit	33
7	Kadri Kadriu	19
8	Mihal Grameno	30
9	Pandeli Sotiri	23
10	Xheladin Rekaliu	40
Total		300

Research Design and Procedure

The following points summarise the procedural steps and the research's design:

1. First, a draft research proposal was submitted to the Ministry of Education, Science, and Technology (MEST) in Kosovo to obtain their agreement and official approval regarding the application of the questionnaire in schools.
2. The authors' permissions were requested from the authors, including the representative author of QTSI and the professor of education at the Faculty of Social and Behavioral Sciences at Utrecht University in Holland.
3. After obtaining an official permit from Prof. Wubbles, the translation process was started. The content validity of the questionnaire (Fraser, Aldridge, & Soerjaningsih, 2010) was achieved through an interdisciplinary evaluation committee consisting of linguists, pedagogues, and psychologists in the Faculty of Education of the University of Prishtina. The commission revised and adapted the first version translated into Albanian. Then the questionnaire was submitted for back translation procedure.
4. The construct validity and reliability of the questionnaire (Fraser et al., 2010) were achieved through statistical procedures.
5. The questionnaire was conducted in two phases: 1) the pilot phase (consisting of 50 respondents), and 2) the total administration phase (consisting of up to 300 subjects involved).

6. Particular attention was paid to the words used, as the answers depend on how the questions are understood (Fraser et al., 2010). After the pilot phase, the commission revised the questionnaire and consequently modified some of the questions, as the pilot results indicated that students found it difficult to understand the questions in which advanced expressions were used relative to their age and cognitive development.
7. The design of the study was completely randomised, and subjects were randomly selected (Fraser et al., 2010; Trochim, 2002).
8. The application procedure was conducted by previously trained students from the Faculty of Education.
9. The study procedure lasted six intensive months (November 2016–April 2017).

Data analysis

For the statistical data processing and analyses, the SPSS 22, AMOS 24 and Oriana 4 software were used. The following analyses were conducted:

1. First, **the distribution of data** was checked to determine which statistical analysis are the most appropriate. The data distribution was analysed through measures of Skewness and Kurtosis. The normality or symmetric distribution was determined by calculating **z-values** for each sub-test. Shapiro-Wilk and Kolmogorov-Smirnov tests were also taken into account.
2. **Factor analysis** with **Barlett** and **KaiserMeyer-Olkin tests (KMO)** to measure the internal validity of the instrument.
3. **Alpha Cronbach** to measure the reliability of the instrument.
4. **Pearson's linear bivariate correlation** to measure the correlation between sub-tests.
5. **Kuiper Test** to measure circumplex distribution.
6. Inferential **ANOVA** and **Eta squared** statistics to measure perception differences between classes.
7. **Univariate analysis** was used to generate an overview of students' perceptions of teachers' interaction habits.

Results

Normal Distribution

The sample consisted of 300 students divided by the age groups from the 1st to the 5th grades. They came from 10 different schools and had 49 different teachers (49 classes in total). Therefore, the data distribution of QTSI subtests was done by selecting each age group in relation to the respective teacher. These data turned out to be normally distributed. It is noteworthy that the Shapiro-Wilk test was more frequently taken into consideration since it appeared to be statistically more sensitive and more appropriate to the current sample size (Statistical Solutions, 2017).

To increase the quality of the data, data cleansing and transformation was conducted. Data cleansing was done by identifying outliers by following the z-values of ± 3 . To exclude outliers, they were transformed into missing values, and then all the missing values were transformed to the mean series' values. In this case, the criteria that the frequency of transformed values to the mean series should not be greater than 5% was taken into account (Hinton, Brownlow, McMurray, & Cozens, 2004). After this data rearrangement, further data transformation was done through the Box-Cox method. With reference to this, traditional arithmetic methods such as 'square root \sqrt{x} ' and ' \log_{10} ', among others, were excluded. Thus, the Box-Cox method was selected as a more advanced one (Osborne, 2010). After this transformation process, the subtests as holistic ones (i.e., the level of study not based on different teachers) resulted in being normally distributed.

Factor analysis with Barlett and Kaiser Meyer-Olkin tests

Before starting factor analyses, Barlett's test for sphericity was conducted to determine whether there is a correlation between variables. The test result turned out to be of statistical significance. It was like a green light for continuing the factorial analysis since variables could be attributed to particular factors. The value of $p \leq .05$ in the Barlett test indicates that the responses collected about the issue being addressed are adequate.

To further confirm the goodness of fit of the sample in order to use the factor analysis, the Kaiser-Meyer-Olkin test was applied. In general, small test values always indicate problems related to the sample; since the correct values should be above .5 (Kaiser, 1974). Thus, the result shown in Table 4 indicates that the sample was appropriate; therefore, the factor analysis could be applied.

Table 4
Results from KMO the Bartlett tests

Kaiser-Meyer-Olkin Measure of Sampling Adequacy.			.73
Bartlett's Test of Sphericity	Approx. Chi-Square 5789.596	DF2016	Sig. .00

There are two types of factorial analysis: exploratory factor analysis (EFA) and confirmatory factor analysis. The analysis offered by SPSS software is EFA. Since an instrument is being adopted but not constructed, CFA had to be used in this study. This analysis presents a more complex approach by testing the hypothesis that questions/items are related to particular factors (Pallant, 2013). So it tends to confirm an already developed model. This analysis should use the structural equation modelling that is not provided with the SPSS program. Therefore, AMOS 24.0 software was used. This is added to SPSS and is particularly suitable for modelling structural equations; calculations can also be done by manually drawing graphical models (Statistical Solutions, 2017). For the use of this analysis in the current study, it is ensured that the variables are of continuous-scale and that the sample size is appropriate. Since the population of 'The Low Primary School Students' in Kosovo is 273,649 (Mekolli et al., 2017), then according to online software for sample size calculation, the sample of 259 subjects was shown to be adequate with 95% confidence level and interval 6 (Survey Systems, 2017). However, in the AMOS software, within the Input's Covariance Matrix, the Bootstrap option was used to increase the measuring accuracy (Arbuckle, 2013). The Boots Factor increased from 1 to 4, which enabled the software to quadruple the sample size by using every observation four times. This was done due to the Chi-square Model Fit Analysis that requires a large number of subjects (mainly over 1000 subjects) (Arbuckle, 2013). Figures 3, 4, and 5 present an example of the model charts for some of the sub-tests and total QTSI-Albanian version.

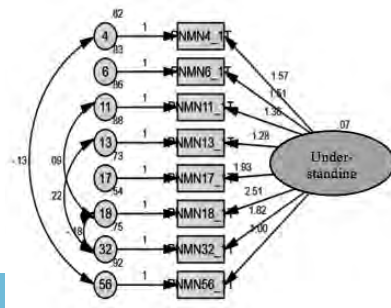

Figure 3. Sub-test 'Understanding'

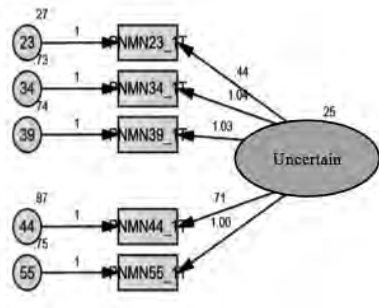

Figure 4. Sub-test 'Uncertain'

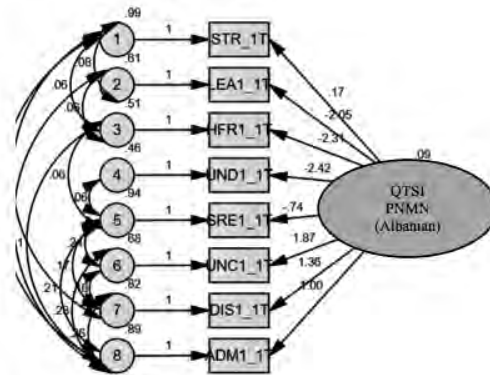

Figure 5. QTSI test with its sub-tests

In all results, the links between the indicator and latent variables can be noticed, and regression weights are always high and/or moderate. Similarly, the covariance between items is addressed. On this basis, some modifications have been made.

Ten (10) items/questions were removed as they were considered unnecessary due to their high covariance with other ones. These items were considered adequately represented through other similar questions. The removed questions/items were 9, 10, 24, 27, 41, 42, 46, 59, 61, and 62. Thus, the QTSI-Albanian version remains with 54 items/questions in contrast to the original version's 64.

The following statistical tests/analyses are conducted to verify the goodness of fit for each sub-test and for the entire instrument:

1. Chi-Square tests,
2. The Goodness of Fit (GFI),
3. Adjusted Goodness of Fit (AGFI),
4. Comparative Fit Index (CFI),
5. Less frequent root mean square error of approximation (RMSEA), and
6. Tucker and Lewis Index (TLI).

All results from these analyses show maximum adaptability/suitability between the Albanian version of QTSI and the original one.

Table 5 presents the results of the above-mentioned analyses for each subtest and for the whole instrument.

Table 5
Goodness of Fit indexes for the QTSI Albanian version

Model Fit Analyses <i>Prop. level</i>	Strict	Leader	Helping-Friendly	Understanding	Student Responsibility	Uncertain	Dissatisfied	Admonishing	Total QTSI	Standard Values
Chi-Square	.10	.12	.81	.97	.83	.69	.74	.96	.35	≥.05
GFI	.99	.98	.99	.99	.99	.99	.99	1.00	.99	≥.90
AGFI	.97	.95	.97	.98	.99	.98	.97	.99	.96	≥.90
RMSEA	.00	.04	.00	.00	.00	.00	.00	.00	.02	≤.05
CFI	1.00	.96	1.00	1.00	1.00	1.00	1.00	1.00	.99	≥.90
TLI	1.07	.93	1.06	1.07	1.11	1.02	1.02	1.04	.93	≥.90

It is noteworthy that the high Goodness of Fit values on the entire QTSI-Albanian version also confirm the circumplex nature/model of the instrument (Tinsley & Brown, 2000; Tracey, 2000).

Reliability of the QTSI-Albanian version

It should be noted that the reliability of an instrument is closely related to its validity (Tavakol & Dennick, 2011). Therefore, the factor analysis was first completed with a view to the model's goodness of fit to be then followed by the reliability analysis.

To verify the instrument's reliability, the standard analysis developed by Lee Cronbach (1951) was used. The Alpha Cronbach coefficient indicates the extent to which (0 to 1) there is internal consistency within the instrument. So, this analysis measures the link between items/questions and how these items consistently measure the same topic (Tavakol & Dennick, 2011).

The Alpha Cronbach coefficients shown in Table 6 meets the acceptance criteria for each sub-test (ranging from about .6 to .7) and are at a satisfactory level for the entire instrument (over .7) (Hair, Anderson, Tatham, & Black, 2006; Hinton, Brownlow, McMurray, & Cozens, 2004).

Table 6

Alpha Cronbach results for all sub-tests and the entire test

Subtest	Item number	Alpha (α) Cronbach
Strict	8	.55-.60
Leader	7	.59-.60
Helpful-friendly	8	.60
Understanding	8	.67-.70
Student responsible	6	.56-.60
Uncertain	5	.55-.60
Dissatisfied	7	.69-.70
Admonishing	5	.67-.70
Total QTSI	54	.74

Generally, in cases in which the test consists of few items (usually less than 10), the Alpha Cronbach (α) results are low and, in these cases, it is better to prove the reliability of the test through the inter-item correlation matrix (Pallant, 2011). This analysis was done for all sub-tests of the QTSI-Albanian version, and no negative values were found.

Positive values indicate that questions measure the characteristics for which they are designed. The inter-item correlation means for each subtest in the Summary Item Statistics Table were shown to be within normal limits of .2 to .4 (Briggs & Cheek, 1986).

Linear bivariate correlation

Since the beginning, the QTSI instrument has had eight sub-tests to measure the teacher-student interaction, and these sub-tests function in circplex in the clockwise direction. Related subtests have a higher correlation with each other, and this correlation is relative to the distance that the subtests are from each other (Den Brok et al., 2006). In this case, Pearson's linear bivariate correlation was applied to measure and prove the correlation between sub-tests.

Correlation results indicate that the QTSI-Albanian version also has a circular nature. The results are as follows:

1. Positive correlation between 'Leader' – 'Supportive/Friendly' sub-tests (n = 250, r = .804, critical value for sample $\pm .124$).
2. Positive correlation 'Supportive/Friendly' – 'Understandable' (n = 250, r = .700, critical value $\pm .124$).
3. Positive correlation 'Leader' – 'Understandable' (n = 250, r = .650, critical value $\pm .124$).

4. Positive correlation 'Understandable' – 'Responsible' (n = 250, r = .605, critical value $\pm .124$),
5. Positive correlation 'Uncertain' – 'Unsatisfied' (n = 250, r = .590, critical value $\pm .124$),
6. Positive correlation 'Unsatisfied' – 'Admonishing' (n = 250, r = .560, critical value $\pm .124$),
7. Positive correlation 'Admonishing' – 'Strict' (n = 250, r = .650, critical value $\pm .124$),
8. Negative correlation 'Understandable' vs. 'Unsatisfied' sub-tests, (n = 250, r = $-.900$, critical value $\pm .124$).

Furthermore, there is no correlation between more distant sub-tests since the correlation value (r) is lower than the critical value for the current sample (Fortlewis Faculty, 2017), which indicates that the correlation scores are not significant. The following sub-tests have shown these results:

1. 'Understandable' - 'Unsatisfied' (n = 250, r = .100, critical value $\pm .124$),
2. 'Uncertain' – 'Leader' (n = 250, r = $-.030$, critical value $\pm .124$),
3. 'Unsatisfied' – 'Supportive/friendly' (n = 250, r = .010, critical value $\pm .124$).

The circular flow of correlations between the subtests is shown in Figure 6 below.

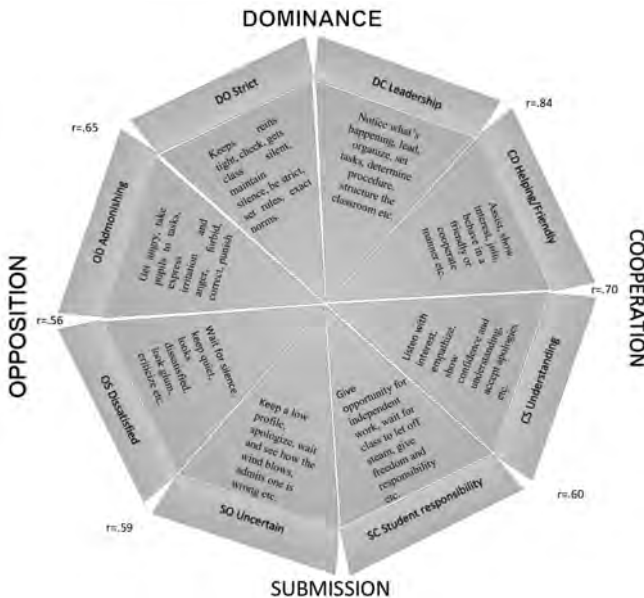

Figure 6. Correlations between subtests as evidence of circular form.

Tests for Measuring Circularity

Circumplex models are widely applied in many psychological fields, including those of interpersonal behaviour, personality traits, emotional/affective domain, and others (Tracey, 2000). Therefore, a special psychometric approach has been developed for measuring those models. Two main approaches for the description and analysis of circular data are found in the literature: a descriptive approach for evaluating the circular models and a confirmatory approach for evaluating the circumplex models. The first approach uses two types of methods: visual inspection (Visualization of Correlation' Matrices and Plotted Factor Scores charts, such as PFA, CFA) and statistical analyses (Kuiper Test, Rayleigh, Selkirk-NeaveGap, etc.), while the second approach uses: constrained multi-dimensional scaling (MDS) and structural equation modelling (eligibility indexes, such as RMSEA, GFI, TLI, etc.) (Tinsley & Brown, 2000; Tracey, 2000).

The circumplex nature of the QTSI-Albanian version was verified through the analysis following the confirmatory approach and presented above. Thus, the circumplex nature is confirmed by the GFI, RMSEA, TLI, CFI goodness of fit to the model indexes, as well as by the matrix correlation data (presented in Table 5 and Figure 6).

To validate even statistically this circular flow, the Kuiper's statistical test was used. Since the formula of this test was inapplicable within the SPSS 22 program, version 4 of the Oriana statistical program was used. Oriana is a program designed for Microsoft Windows that primarily addresses the orientations as well as other circular data (Oriana, User's Manual, 2011). For example, unlike regular factor load models, in which the sub-tests are designed to rely on only one factor; in the case of QTSI, the different sub-tests of the X-Y axes (Proximity and Impact) are calculated by being linearly transformed depending on their interpersonal position under the coordinate axis (Wubbels et al., 2012). The Oriana software provides statistical tests, such as the Rayleigh and Kuiper tests, which are highly sensitive to the data characteristics that have a circular flow. Kuiper's test is one kind of test that measures the distribution similar to that of Komorglav-Smirnov, but Kuiper has incorporated into its formula the measure of the inconsistency values that represent the absolute values of the extreme positive and negative differences; so as a result, this test is sensitive to the edges of distribution (unlike that of Komorglav-Smirnov) (Arsham, 1988).

Thus, Kuiper is based on the largest vertical deviations above and below the diagonal line (representing the desired distribution). That is why the Kuiper test is irreplaceable in circular measurements as it can detect the data value extensions (Arsham, 1988; Oriana User's Manual, 2011).

The results of this test for all sub-tests are as follows: 'Strict' (n = 250, k = 1.70, p ≤ .065), 'Leader' (n = 250, k = 1.68, p ≤ .073), 'Supportive/Friendly' (n = 250, k = 1.74, p ≤ .052), 'Understandable' (n = 250, k = 1.72, p ≤ .058), 'Responsible' (N = 250, k = 1.66, p < .081), 'Uncertain' (n = 250, k = 1.68, p ≤ .073), 'Unsatisfied' (n = 250, k = 1.72, p ≤ .058), and 'Admonishing' (n=250, k=1.66, p ≤ .081). These results show that there is a tendency of uniform data flow, somehow evidencing the circular data flow.

Inferential ANOVA and Eta squared statistics

Another essential characteristic of the QTSI instrument is its ability to differentiate between perceptions of students in different classes. Students within the same class should perceive approximately the same interpersonal relationships with their teacher, while the mean of these perceptions should vary from class to class as the teacher is different (Fisher & Rickards, 1998; Richards & Fisher, 2000).

One-Way ANOVA with the class as the main effect was applied to validate the differences between the groups' means (in total, 48 different classes), while Eta Squared was used to prove that the class is the indicator that represents the difference between these means, by verifying first that the sample size is adequate.

Table 7 of the One-Way ANOVA shows that in each sub-test of the QTSI, the result (p < .001) significantly differentiates between the classes, while the Eta Squared results (shown in Table 8) varied from 0.35 to 0.54, showing the proportion of the variance, based on classes is under the acceptable limits of sample size effect (Preacher & Kelley, 2011).

Table 7

One-Way ANOVA results of all subtest

Subtests with the class as the main effect	ANOVA Results
Strict * Class	F (48, 210)=4,44; p=.00
Leader * Class	F (48, 210)=2,71; p=.00
Friendly/ Supportive * Class	F (48, 210)=3,25; p=.00
Understanding * Class	F (48, 210)=5,24; p=.00
Responsible * Class	F (48, 210)=2,94; p=.00
Uncertain * Class	F (48, 210)=3,93; p=.00
Dissatisfied * Class	F (48, 210)=3,97; p=.00
Admonishing * Class	F (48, 210)=2,33; p=.00

Table 8
Eta and Eta Squared results

Subtests with class as a main effect	Eta	Eta Squared
Strict * Class	.71	.50
Leader * Class	.61	.38
Friendly/ Supportive * Class	.65	.42
Understanding* Class	.73	.54
Responsible * Class	.63	.40
Uncertain * Class	.68	.47
Dissatisfied * Class	.69	.47
Admonishing * Class	.58	.34

The Albanian version of QTSI and perception of teachers by primary school students in Kosovo

Results related to the perception of teacher-student relationships were generated through univariate analysis: Central Tendency (Mean) and Dispersion (Standard Deviation). Table 9 below shows the results for each subtest. The results demonstrate that the students perceive their teachers more as leaders ($\mu = 4.4$), understandable ($\mu = 4.1$), supportive and friendly ($\mu = 3.9$) and less unsatisfied ($\mu = 1.8$), uncertain ($\mu = 1.4$) and Admonishing ($\mu = 1.7$). However, teachers are largely perceived as responsible ($\mu = 2.6$) and with strict behaviours ($\mu = 2.4$).

Table 9
Descriptive statistics upon the perception of student-teacher relationships

	N	Min.	Max	(μ)	(σ)
Strict	258	1.10	3.80	2.45	.47
Leader	259	1.00	5.00	4.40	.56
Friendly/Supportive	259	1.00	5.20	3.98	.62
Understanding	259	1.00	5.00	4.13	.67
Responsible	259	1.00	4.75	2.64	.61
Uncertain	259	1.00	5.00	1.48	.49
Dissatisfied	259	1.00	3.78	1.80	.58
Admonishing	259	1.00	3.75	1.78	.54
Valid N (listwise)	258				

Discussion of the results and conclusion

The purpose of this study was primarily to adopt the American version of QTSI in Albanian language and the provision of the general overview of the perceptions of teachers by elementary school students in Kosovo. Permission to adapt this instrument was granted by the QTSI's author, while the approval for its application was granted by MEST in Kosovo. The translation of the questionnaire passed through several stages: a professional translation was conducted, and the verification of questionnaire's content validity was done through a professional commission as well as the back translation and other necessary statistical procedures.

Intensive support was provided to students during the administration of the questionnaire to ensure that the questions were well understood; all questions that were not sufficiently understandable due to linguistic, cultural, or even certain developmental periods were identified during the administration phases. The goal was an instrument that satisfies psychometric expectations regarding questionnaires' adaptation. In addition to the application of Goodness of Fit Indexes through CFA and the Alpha Cronbach reliability, correlations between the sub-tests and the Kuiper test were also required to confirm the circumplex nature of the instrument. All Goodness of Fit to the model indexes were shown within the acceptable limits. Acceptable results on Goodness of Fit indexes were also indicators to confirm the original circumplex nature of the instrument. However, its circumplex nature was also verified by proving inter-scale correlations through Pearson's bivariate correlation analysis and the Kuiper statistical test.

During the factorial analysis procedure, it was decided that ten (10) items should be excluded from the adopted Albanian instrument as they were presented sufficiently through other similar questions having covariance to a great extent. Thus, the Albanian version of the QTSI was reduced to 54 questions. However, the alpha reliability coefficient at sub-tests level did not often prove to be of high value, but moderately acceptable. It is worth mentioning that the alpha coefficient is sensitive to the number of the items in the instrument (Pallant, 2011, 2013; Tavakol & Dennick, 2011), whereas the assumption behind the alpha equation is that the specific variance within the variables (s^2) should be smaller than the inter-item variance in the instrument (Cov) in order to present a high internal consistency (Cortina, 1993). As the ten questions with high covariance values were removed from the Albanian version of the instrument, this should be the main reason that Alfa Cronbach results of QTSI sub-tests in Albanian were higher before excluding those 10 questions identified

with the Confirmatory Factor Analysis. However, based on: the fact that a good instrument (including its administrative aspect) is one that has a small number of questions but sufficiently measures what it is designed for (Wubbles & Brekelmans, 2005; Wubbels et al., 2012) and the general tendency to reduce questions from the QTSI questionnaire (Fisher & Richards, 1998), it was decided that the items to be excluded. Again, Alpha Cronbach coefficients were in the eligibility criteria for all sub-tests. Also, the inter-item correlation matrix proved that the inter-item correlation means were within the acceptable limits (Briggs & Cheek, 1986; Pallant, 2011).

The application of QTSI-Albanian version in the current sample of Kosovo primary school students once again proves that the students perceive their teachers differently. This perception depends on the nature of interpersonal relationships developed by teachers (Fisher & Rickards, 1998; Richards & Fisher, 2000). One-Way ANOVA and Eta Squared analysis has shown a significant statistical difference between perceptions of teachers by students of different classrooms. The ability to differentiate between classrooms is again in line with the original research and previous validation studies of QTSI (Passini et al., 2015; Wubbles et al., 2005).

In general, students in Kosovo perceive their teachers as leaders who are understandable, supportive, and friendly. Teachers are seen as less unsatisfied, uncertain, and admonishing. However, they are largely perceived as responsible and with strict behavior. In this direction, according to the results from univariate analyses, we may conclude that students perceive their teachers more in the dimensions of dominance (e.g., leader, strict) and cooperation (e.g., understandable, supportive-friendly). It can be interpreted so that teachers imply influence on their students, but, at the same time, they establish an amount of cooperation. Regardless, our study presented merely superficial results of this nature since its primary purpose was to properly adapt the questionnaire. We recommend that student-teacher interaction in Kosovo schools should be further studied in order to better explore the nature of this interaction and to evaluate scientifically the students' academic achievements and motivation.

From what has been presented thus far through this paper, it can be concluded that the QTSI-Albanian version is valid and reliable. This instrument is an additional asset in the Albanian language since it is the first validated one that measures teacher-student interaction. In general, the instrument can contribute to a deeper understanding of the teacher-student relationships and the impact they have on different educational and developmental areas within Albanian samples. It can be used by teachers, specifically as a tool for helping reflective thinking related to classroom practice improvements. Taking into

account the fact that teachers sometimes tend to lack reflective ability because the teaching process and interaction with students becomes reflexive everyday responses (Choy & Oo, 2012), the questionnaire's ability to stimulate thinking upon the differentiated results from QTSI on the 'Ideal Self', 'Real Self', and 'Self-perceived by students' may support reflection on teacher's professional work (Fisher & Rickards, 1995, 1998). This may be the most valuable contribution that the application of the QTSI-Albanian version could give to the education system in Kosovo, since enabling reflective teaching is a targeted milestone intensively addressed during the last decade in the country (Berisha Kida, 2017; MEST, 2016; 2017).

References

- Arbuckle, L. (2013). *Amos 22.0 user's guide*. Chicago, IL: IBM SPSS.
- Arsham, H. (1988). Kuiper's p-value as a measuring tool and decision procedure for the goodness-of-fit test. *Journal of Applied Statistics*, 15(2), 131–135.
- Berisha Kida, E. (2017). *Teachers' Emotions and Professional Reflection in a Postwar Community*. ICPAS (pp. 190–197). Istanbul: Yildiz Technical University. doi:10.13140/RG.2.2.31674.08647
- Briggs, S. R., & Cheek, J. M. (1986). The role of factor analysis in the development and evaluation of personality scales. *Journal of Personality*, 54(1), 48–106.
- Choy, Ch. S., & Oo, S. P. (2012). Reflective thinking and teaching practices: A precursor for incorporating critical thinking into the classroom? *International Journal of Instruction*, (5)1, 167–182.
- Cortina, J. M. (1993). What is the coefficient alpha? An examination of theory and application. *Journal of Applied Psychology*, 78(1), 98–104.
- Den Brok, P. (2001). *Teaching and student outcomes: A study on teachers' thoughts and actions from an interpersonal and a learning activities perspective*. Utrecht: W.C.C.
- Den Brok, P., Fisher, D., & Rickards, T. (2006). Factors influencing students' perceptions of their teachers' interpersonal behavior: A multilevel analysis. In D. L. Khine (Ed.), *Contemporary approaches to research on learning environments: world views* (pp. 2–36). Singapore: World Scientific. doi:10.1142/9789812774651_0003
- Erikson, E. (1959). *Identity and the life cycle: Selected papers*. New York, NY: International Universities Press.
- Erikson, E. (1963). *Childhood and society* (2nd ed.). New York, NY: Norton.
- Fisher, D., & Rickards, T. (1998). Associations between teacher-student interpersonal behaviour and student attitude to mathematics. *Mathematics Education Research Journal*, 10(1), 3–15.
- Fisher, D., Fraser, B., & Cresswell, J. (1995). Using the 'Questionnaire on Teacher Interaction' in the professional development of teachers. *Australian Journal of Teacher Education*, 20(1), 8–18.
- Fort Lewis Faculty. (2017). *Table of critical values for Pearson correlation*. Durango, CO: Fort Lewis College. Retrieved from http://faculty.fortlewis.edu/chew_b/Documents/Table%20of%20critical%20

values%20of%20Pearson%20correlation.htm

Fraser, B., Aldridge, J., & Soerjaningsih, W. (2010). Instructor-student interpersonal interaction and student outcomes at the university level in Indonesia. *The Open Education Journal*, 3(1), 21–33.

Frenzel, A. C., Goetz, T., Lüdtke, O., Pekrun, R., & Sutton, R. E. (2009). Emotional transmission in the classroom: Exploring the relationship between teacher and student's enjoyment. *Journal of Educational Psychology*, 101(1), 705–716.

Fried, L., Mansfield, C., & Dobozy, E. (2015). Teacher Emotion Research: Introducing a conceptual model to guide future research. *Issues in Educational Research*, 25(4), 415–440.

Ginsburg, H. & Opper, S. (1969). *Piaget's theory of intellectual development*. New York, NY: Prentice Hall.

Hair, J., Anderson, R., Tatham, R., & Black, W. (2006). *Multivariate Data Analysis*. New Jersey, NJ: Pearson/Prentice Hall.

Hinton, P. R., Brownlow, Ch., McMurray, L., & Cozens, B. (2004). *SPSS explained*. London, UK & New York, NY: Routledge.

Kaiser, H. F. (1974). An index of factorial simplicity. *Psychometrika*, 39(1), 31–36.

Leary, T. (1957). *Interpersonal diagnosis of personality: A functional theory and methodology for personality evaluation*. New York, NY: Ronald Press.

Liberante, L. (2012). The importance of teacher-student relationships, as explored through the lens of the NSW quality teaching model. *Journal of Student Engagement: Education Matters*, 2(1), 2–9.

Mekolli, E., Bruqi, Sh., Lahi, H., Rexhepi, N., Faliu, M., Radoni, S., & Cakolli, A. (2017). *Statistics of Education 2015/2016*. Prishtine: ASK.

MEST. (2016). *Strategjia e Sigurimit të cilësisë për arsimin parauniversitar në Kosovë* [Quality Assurance Strategy for Pre-University Education in Kosovo]. Prishtine: MEST. Retrieved from <https://masht.rks-gov.net/uploads/2016/12/qa-strategy-final-shqip.pdf>

MEST. (2017). *Kornizë strategjike për zhvillimin e mësimdhënësve në Kosovë* [Strategic framework for teacher development in Kosovo]. Prishtinë: MEST. Retrieved from <https://masht.rks-gov.net/uploads/2017/04/kornize-strategjike.pdf>

Muller, C., Katz, S. R., & Dance, L. J. (1999). Investing in teaching and learning dynamics of the teacher-student relationship from each actor's perspective. *Urban Education*, 34(3), 292–337.

Oriana, User's Manual. (2011). Wales, UK: Kovach Computing Services.

Osborne, J. (2010, October). Improving your data transformations: Applying the Box-Cox Transformation. *Practical Assessment, Research, and Evaluation*, 15(12), 1–8.

Pallant, J. (2011). *SPSS survival manual. A Step by step guide data to analysis using SPSS-4th edition*. Maryborough: Midland Typesetters.

Pallant, J. (2013). *SPSS survival manual*. London, UK: McGraw-Hill Education.

Passini, S., Molinari, L., & Speltini, G. (2015). Validation of the questionnaire on teacher interaction in Italian secondary school students: The effect of positive relations on motivation and academic achievement. *Social Psychology of Education*, 18(3), 547–559.

Preacher, K. J., & Kelley, K. (2011). Effect size measures for mediation models: Quantitative strategies

- for communicating indirect effects. *Psychological Methods*, 2(16), 93–115.
- Richards, T., & Fisher, D. (2000). *Three perspectives on perceptions of teacher-student interaction: A seed for change in science teaching*. Retrieved from <http://files.eric.ed.gov/fulltext/ED441758.pdf>
- Statistical Solutions*. (2017). Retrieved from <http://www.statisticssolutions.com/amos/>
- Strack, S. (1996). Introduction to the special series. Interpersonal theory and the interpersonal circumplex: Timothy Leary's legacy. *Journal of Personality Assessment*, 66(2), 212–216.
- SurveySystems*. (2017, August 12). Retrieved from www.surveysystem.com/sscalc.htm
- Tavakol, M., & Dennick, R. (2011). Making sense of Cronbach's alpha. *International Journal of Medical Education*, 2(1), 53–55. doi:10.5116/ijme.4dfb.8dfd
- Tinsley, H. E. A., & Brown, S. D. (2000). *Handbook of applied multivariate statistics and mathematical modelling*. London, UK: Elsevier Science & Technology Books.
- Tracey, T. J. (2000). *Analyses of circumplex models*. Oxford, UK: Academic Press.
- Trochim, W. (2001). *Research methods. Knowledge base*. New York, NY: Cornell University Press.
- Trochim, W. (2002). *The research methods: Knowledge Base*. New York, NY: Cornell University Press.
- Triplet, N. (1987). The dynamogenic factors in pacemaking and competition. *American Journal of Psychology*, 9(1), 506–533.
- Vata, R., Haith, M., & Miller, S. (2007). *Psikologjia e femijes- Shkenca moderne*. Tirane: UEGEN.
- Wubbels, T., & Levy, J. (1991). A comparison of interpersonal behavior of Dutch and American teachers. *International Journal of Intercultural Relations*, 15(1), 1–18.
- Wubbels, T., Brekelmans, M., & Hermans, J. (1987). *Discipline problems of beginning teachers: Interactional teacher behavior mapped out*. Annual Meeting of the American Education Research Association, Chicago, IL.
- Wubbels, T., Créton, H. A., & Hooymayers, H. P. (1985). *Discipline problems of beginning teachers: Interactional behavior mapped out*. Paper presented at the annual meeting of the American Educational Research Association, Chicago, IL.
- Wubbels, Th., Den Brok, P., Van Tartwijk, J., & Levy, J. (2012). *Interpersonal relationships in education: An overview of contemporary research*. In *Advances in learning environments research* (Vol. 3, pp. 5–45). Rotterdam: Sense Publishers.
- Wubbels, Th., & Brekelmans, M. (2005). Two decades of research on teacher-student relationships in class. *International Journal of Educational Research*, 43(1), 6–24.

Biographical note

EDONA BERISHA KIDA has a PhD in psychology, finished in Tirana University-Albania. Her research interests are mainly in the field of clinical and educational psychology with current research focusing on trauma transmission through education system. Prior to her PhD, she studied at Pristine University, where she completed a M.Sc. degree in Child/School Clinical Psychology. Her main orientation is in cognitive behavioural therapy. She lectures psychology subjects at Faculty of Education/Pristine University. During 2008-2009 she has successfully finished one-year training on Higher Education Academic Practice at University of Bedfordshire/England. She was also actively involved in establishing national policies for preventing and eliminating worst forms of child labour (including trafficking) in Kosovo.

THEODHORI KARAJ, PhD, is a full professor at the Department of Psychology and Education, Faculty of Social Sciences, University of Tirana, Albania. His main areas of research are: teachers' job stress, job burnout, job satisfaction, stresses coping strategies and motivation; mobbing, peer bullying, cyber bullying and professor bullying in higher education.